

Lateral Flow Reagent Dispenser Instruction Manual



1182 Monte Vista Ave. Suite #11 • Claremont, CA 91786
Phone: 909-920-3887 • Fax: 909-946-1132

Specifications

Dimensions (L x W x H): 457 x 146 x 75 mm (excluding power supply and syringe pump)

Weight: 2.2 kg

Power: Adjustable to AC/DC Adapter
120 VAC: 3 - 12V

Dispense Area (L x W): 302 x 64 mm

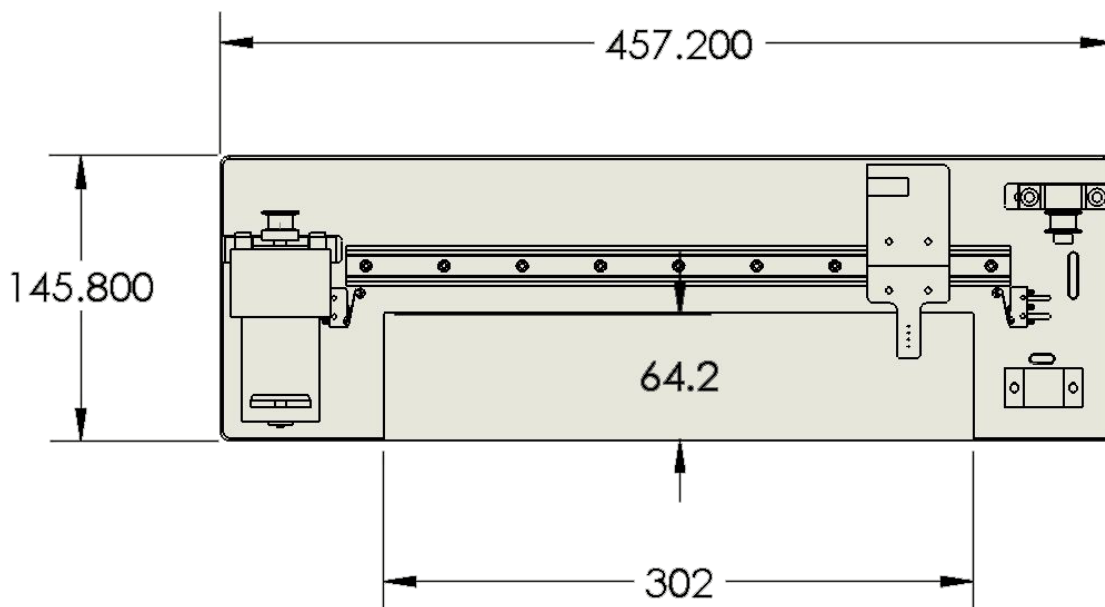

Instructions for Use

1. Plug in and turn on Lateral Flow Reagent Dispenser (LFRD) unit and external syringe pump.
2. Program syringe pump flow rate according to manufacturer's instructions.
 - a. See Appendix A, Figure 1 for recommended flow rates.
 - b. See Appendix B for programming instructions for ClaremontBio's syringe pump.
3. Select voltage on power supply. Use 12v for maximum speed.
 - a. See Appendix A, Figure 2 for voltage dependence on head speed.
 - b. If a faster head speed is desired, a power supply can be connected in lieu of the provided power supply; however, 24v is the maximum voltage that can be used for the LFRD.
4. Secure dispense tips into desired placement slot on dispense tip head using provided Allen wrench.
 - a. For best results, position tips very close to the membrane surface, without direct contact (unless contact is desired).
 - i. Actual height is dependent on membrane type and thickness.
 - b. Tips positioned too high may result in liquid droplet formation.
 - c. To test positioning, place membrane on dispense table and initiate switch to cause table to move. Drag on membrane will be apparent.
 - i. Once desired height is established, it may be helpful to mark position on metal post of dispense tip with a permanent marker.
5. Once dispense reagents have been prepared, remove air bubbles prior to use in LFRD (i.e. quick centrifugation, nitrogen air purge).
 - a. A volume of 200 μ l or greater is recommended.

- b. When solution is running out during dispensing, lines will appear thinner and may produce varying results.
6. Draw up each solution into a syringe, taking care to minimize air bubbles.
7. Attach tubing to blunt syringe needle and secure filled syringes on syringe pump according to manufacturer's instructions.
8. Turn on syringe pump to prime solution(s) through tubing and dispense. Turn off pump and wipe away residual liquid.
9. Secure membrane on LFRD dispense table using magnets.
10. Turn on syringe pump, followed immediately by dispense table switch.
11. Once dispense tips have reached the end of the table and stopped, turn off syringe pump.
12. Remove membrane from table.
13. Return dispense tips to their original position by reversing the table switch.
14. Wipe off any residual liquid from table.
15. Repeat as necessary.

Recommended Cleaning and Storage Procedure

1. Following reagent dispensing, purge lines of remaining fluid.
2. Rinse several times with dI water.
3. Follow with several washes of 1-10% bleach (if desired).
4. Flush out bleach with dI water.
5. Purge out water and store reagent lines dry.
6. To avoid cross-contamination of reagents, it is recommended to designate a reagent dispense tip / tubing per reagent (cat # 07.811.01).

Appendix A

I. Flow Rate (ml/min)

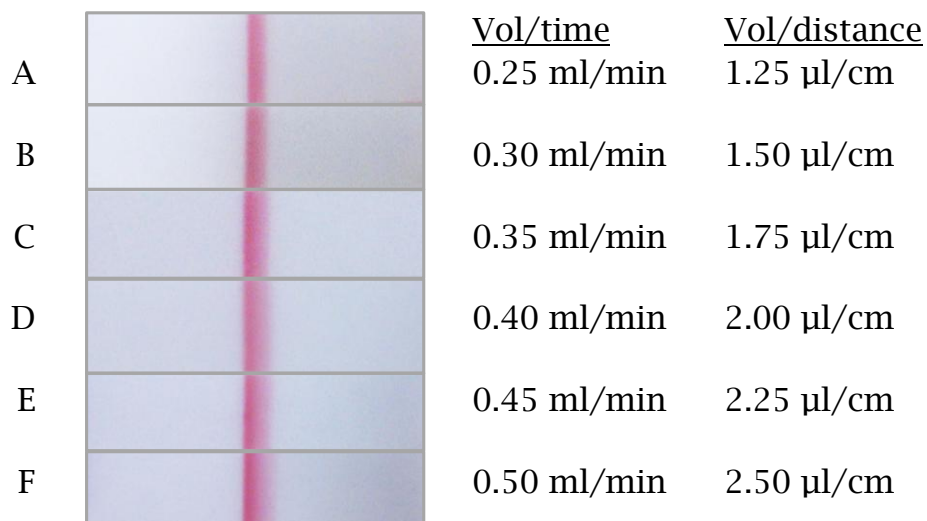

Figure 1: 2 mg/ml Human IgG + 5% Ethanol dispensed on nitrocellulose with LFRD at 12v. Syringe pump flowrate varied from 0.25ml/min (A) to 0.50ml/min (F). High affinity interactions may create an intense front edge, resulting in a capture line that appears less homogeneous; therefore, a slower flow rate may be optimal (A or B), depending upon specific application.

II. Voltage Dependence on Head Speed

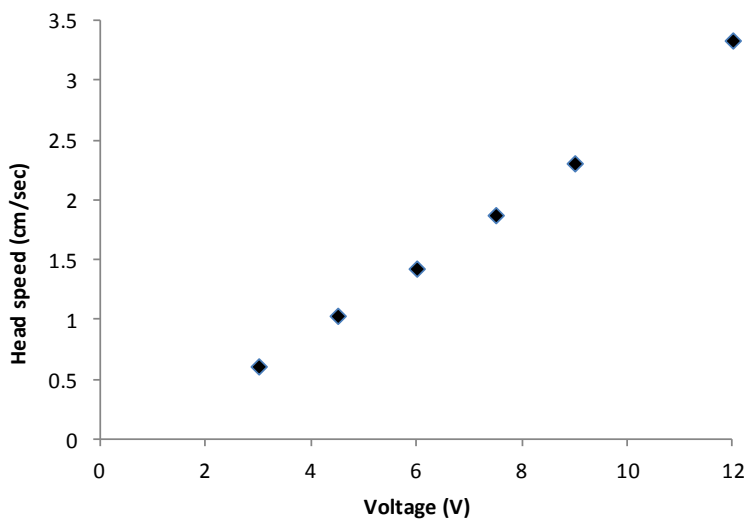

Figure 2: Voltage of LFRD varied from 3 - 12v. Distance travelled = 30 cm

Appendix B:
Instructions for ClaremontBio's Syringe pump
(CBS200 or CBS250)

1. Turn on power at switch located in the back.
2. Programming parameters:
 - a. "Select" *Table*
 - b. "Select" *Bec Dic plastic*
 - c. Arrow (→ ←) to *1cc 4.70 mm* and press "Select"
 - d. Volume: *1 ml*, press "Enter"
 - e. Rate: *xxx ml/min*, press "Enter". Rate is determined by user.
3. Load syringes with dispense reagent and attach tubing.
4. Place syringe in syringe holder and secure with clamp.
5. Put syringe pusher block flush with syringes and lock by turning drive nut knob clockwise.
6. Press "Run" to start dispensing.
7. When dispensing is complete, press "run" again to stop reagent flow.